



Daruifuno

Digital pH Sensor

Basic User Manual



Model: DPH890

Version 1.0

Contents

Chapter 1	Specification	1
Chapter 2	Basic Information	2
2.1	Security Information.....	2
2.2	Overview.....	2
2.3	Dimensions.....	2
Chapter 3	Installation	3
3.1	Sensor Installation.....	3
3.2	Sensor Wiring.....	4
Chapter 4	Communication	5
4.1	Overview of Modbus RTU.....	5
4.2	Corresponding parameter table of communication address.....	7
4.3	How to use common functions.....	9
4.3.1	Reading electrode measurements.....	9
4.3.2	Modify electrode address.....	10
4.3.3	Electrode calibration.....	10
4.3.4	Factory reset.....	10
Chapter 5	Maintenance cycle	11
5.1	Maintenance cycle.....	11
5.2	Common problems and solutions.....	11

Chapter 1 Specification

Product specifications are subject to change without notice.

Measuring principle	Glass electrode method
Measuring range	0.00~14.00 pH 0.0~50.0 °C
Resolution	0.01 pH 0.1 °C
Accuracy	±0.02pH
TEMP compensation method	0 to 50°C, Automatic compensation or Manual compensation
Calibration method	Zero calibration, slope calibration, offset calibration
Operating temperature	0 to 50°C
Work pressure	≤1Bar
Waterproof level	IP68
Power requirements	DC 12V±5%
Power consumption	About 0.2W
Electrical isolation	Power supply and communication are isolated inside the sensor
Communication Interface	RS485 MODBUS
Shell material	Stainless steel 316, POM
Case size	Diameter 37mm, total length about 266mm
Installation size	Can be connected to 1 inch PVC pipe
Weight	Approx. 500g (without cable)
Cable	PUR (polyurethane) sheath, standard 5 meters, can be customized length
Connection method	Bare wire, M12 plug or waterproof aviation plug

Chapter 2 Basic Information

2.1 Security Information

Please read this entire manual before unpacking, installing and operating this equipment. In particular, pay attention to all precautions. Failure to do so may result in serious personal injury to the operator, or damage to the equipment.

2.2 Overview

The digital pH sensor adopts the classic electrochemical principle, with reliable measurement and stable performance. Widely used in environmental protection water treatment, surface water, pure water, circulating water and other systems, as well as electroplating, electronics, printing and dyeing, chemical, food, pharmaceutical and other process fields. Excellent performance in sewage treatment, drinking water treatment, surface water monitoring, pollution source monitoring, industrial process and other applications.

2.3 Dimensions

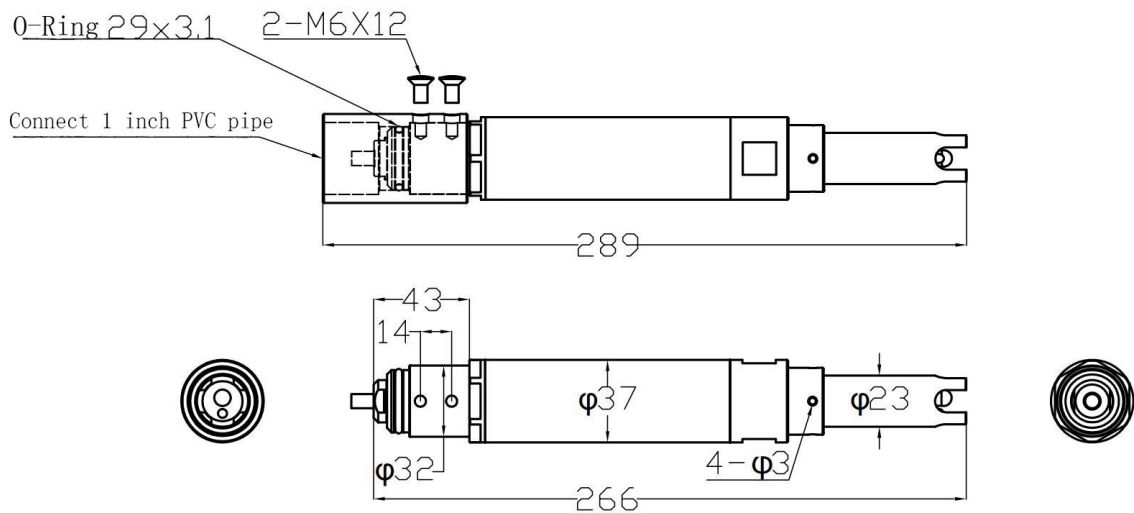

Figure 1 Sensor dimensions

Chapter 3 Installation

3.1 Sensor Installation

Refer to the pictures in this section to install and fix the sensor. To ensure that the sensor can measure safely and accurately, please meet the following conditions during installation:

- Choose a location that is convenient for operation and maintenance to install the sensor, and the pH sensor needs regular maintenance;
- The electrode installation angle is within $\pm 30^\circ$, and the electrodes cannot be installed horizontally or inverted;
- Do not remove the protective cap when installing the electrode on site, and remove the protective cap after the installation is completed and used.

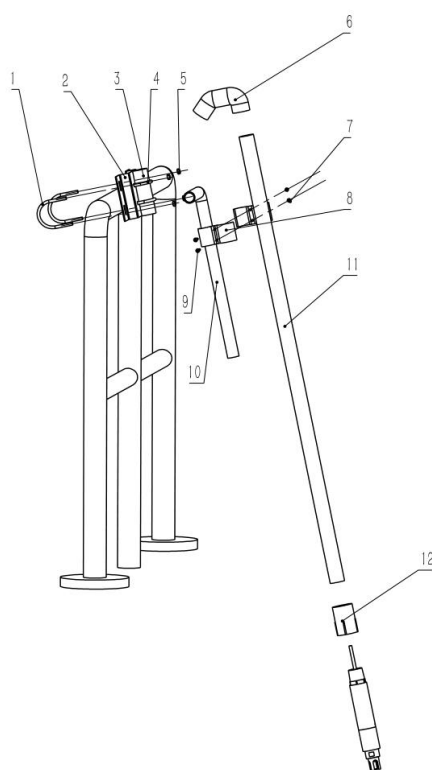

Figure 2 Schematic diagram of railing installation

1- DN60 U-shaped card	7- M4 screw nut*2
2-“└┘” shaped board	8- “8” Shaped clip 25&32
3- Handle sleeve	9- M4*25 screw*2
4- DN40 U-shaped card	10- Handle
5- M6 screw nut*8	11- DN32 PVC Bracket
6- Rain proof elbow	12- 1 inch inner wire straight pipe joint

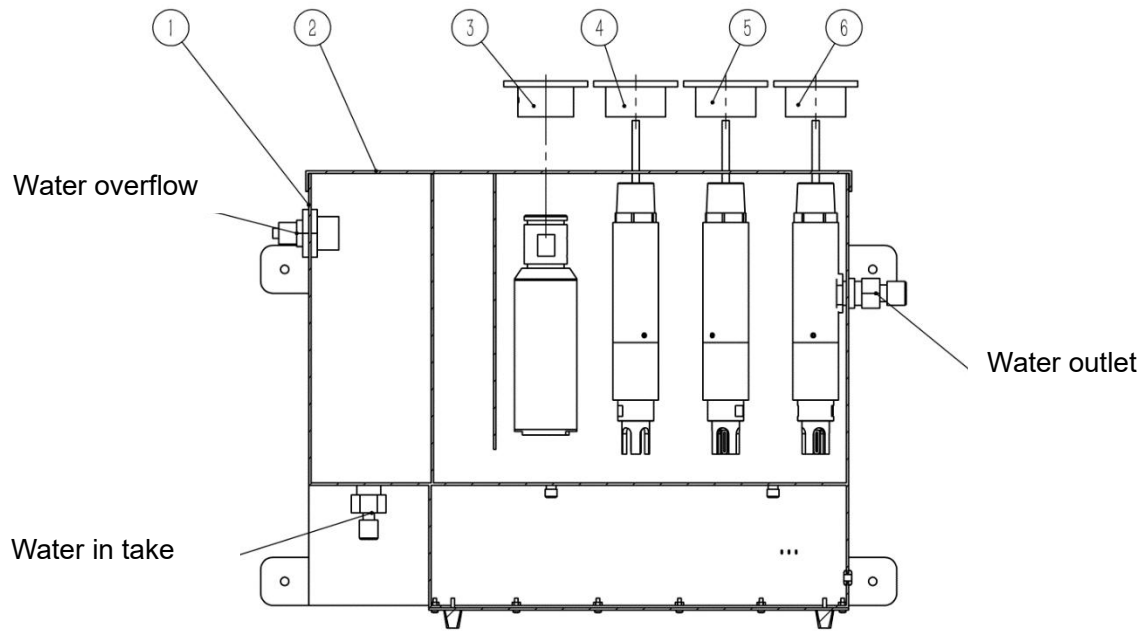

Figure 3 Schematic diagram of five-parameter flow cell installation

1-Flow cell	4-pH sensor fixed connection cover
2-Flow cell cover	5-Dissolved oxygen sensor fixed connection cover
3-Turbidity sensor fixed connection cover	6-Conductivity sensor fixed connection cover

3.2 Sensor Wiring

The sensors are connected correctly as defined in the table below.

Note: Aviation plug version does not require user to connect wires.

Wire Color	Red	Black	White	Green
Terminal Definition	Power positive	Power negative	RS485 data A (+)	RS485 data B (-)
Terminal Symbols	V+	V-	AS	BS

Chapter 4 Communication

4.1 Overview of Modbus RTU

About Modbus RTU overview:

The electrode acts as a slave on the network and supports the Modbus RTU communication protocol.

Data communication is initiated by the host, and the first byte of the transmitted message is the target slave address. After the first byte is received by all the slaves on the network, each slave will decode it to determine whether the message is sent to itself.

The transmission of the RTU message frame shall start with a pause interval of at least 3.5 character time. After the transmission of the last character, a pause of at least 3.5 characters time marks the end of the message frame. A new message can start after this pause. During transmission, the entire message frame must be transmitted in a continuous stream. If there is a pause interval of more than 1.5 character time before the transmission of the message frame is completed, the receiving device will flush the incomplete message and assume that the next byte is the start of a new message. Likewise, if a new message begins with the previous frame within less than 3.5 characters, the receiving device will consider it a continuation of the previous frame, and this will result in an error because the final CRC The value cannot be correct.

The host can send command frames to read individual or all data results.

The data frame format is as follows (all data are in Hex format)

Host sends:

1	2	3	4	5	6	7	8
Slave address	Function code	Register starting address High 8 bit	Register starting address Low 8 bit	Register number High 8 bit	Register number Low 8 bit	CRC Low 8 bit	CRC High 8 bit

The slave responds:

1	2	3	4	5	5+n	5+n+1	5+n+2	5+n+3
Slave address	Function code	Data bytes	Data 1 High 8 bit	Data 1 Low 8 bit	Data n High 8 bit	Data n Low 8 bit	CRC Low 8 bit	CRC High 8 bit

Example:

Send frame: **[01 04 00 02 00 02 D0 0B]**, meaning as follows:

[01]: Slave address

[04]: Function code

[00 02]: The starting address of the register is 0x02

[00 02]: Read 2 registers from the starting address (ie, read 1 single-precision floating-point data result)

[D0 0B]: CRC check data

Return frame: **[01 04 04 00 00 41 C8 CA 42]**, meaning as follows:

[01]: Slave address

[04]: Function code

[04]: The number of bytes returned is 4

[00 00 41 C8]: 41 C8 00 00 (That is, the floating-point value is 25, the specific value meaning is to find the corresponding address)

(Note: Combine two 16-bit integer registers to form a single-precision floating-point number, pay attention to the order of the data)

4.2 Corresponding parameter table of communication address

Main measurement (read with function code 04)					
Parameter	Address	Data Format	Value Range	Initial Value	Instruction
Main measurement	2	32 Bit Float	0~14	-	Unit: pH
Temp. measurement	4	32 Bit Float	0~50	-	Unit: °C

Communication parameters (read with function code 03, write with function code 06)					
Parameter	Address	Data Format	Value range	Initial Value	Instruction
Address	0	Unsigned	1 ~ 254	9	-
Baud rate	1	Unsigned	0 ~ 3	1	0:4800 1:9600 2:19200 3:38400
Check Digit	2	Unsigned	0 ~ 2	0	0: None 1: Even parity 2: odd parity
Stop bit	3	Unsigned	0 ~ 1	1	1:1bit 2:2bit

System setting parameters (read with function code 03, write with function code 06)					
Parameter	Address	Data Format	Value range	Initial Value	Instruction
Sampling rate	4	Unsigned	0~4	2	0: Level 2 buffer 1: Level 4 buffer 2: Level 8 buffer 3: Level 16 buffer 4: Level 32 buffer
Temperature mode	5	Unsigned	0~1	0	0: Automatic 1: Manual
Solution compensation type	6	Unsigned	0~3	0	0: No compensation 1: Natural water 2: Pure water 3: Other

User setting parameters (use function code 03 to read, function code 16 to write)					
Parameter	Address	Data Format	Value range	Initial Value	Instruction
Cal point 1	100	32 Bit Float	3.5<value≤4.51	4.01	The cal point value can be changed, and the setting range is between 3.5 and 4.51
Cal point 2	102	32 Bit Float	6.36<value≤7.5	6.86	The cal point value can be changed, and the setting range is between 6.36 and 7.5
Cal point 3	104	32 Bit Float	8.68<value≤10.5	9.18	The cal point value can be changed, and the setting range is between 8.68 and 10.5
Zero point	106	32 Bit Float	-50 ~ 50	8.28	The value is generated according to user calibration, the zero value can be changed, and the setting range is between -50 and 50
Slope 1	108	32 Bit Float	45 ~ 60	59.16	The value is generated according to user calibration, the slope one value can be changed, and the setting range is between 45 and 60
Slope 2	110	32 Bit Float	45 ~ 60	59.16	The value is generated according to user calibration, the slope two value can be changed, and the setting range is between 45 and 60
Main measure offset	112	32 Bit Float	-14 ~ 14	0	The main measurement offset value can be changed, the setting range is between -14 and 14
Temp offset	114	32 Bit Float	-100 ~ 100	0	The temperature offset value can be changed, the setting range is between -100 and 100
Manual temp value	116	32 Bit Float	0 ~ 100	25	Manual temperature value can be changed, the setting range is between 0 and 100
Natural water compensation coefficient	120	32 Bit Float	0 ~ 1	0.008	The compensation coefficient value can be changed, and the setting range is between 0 and 1
Pure water compensation coefficient	122	32 Bit Float	0 ~ 1	0.015	The compensation coefficient value can be changed, and the setting range is between 0 and 1
Other solution compensation coefficient	124	32 Bit Float	0 ~ 1	0.1	The compensation coefficient value can be changed, and the setting range is between 0 and 1

User calibration parameters (read with function code 03, write with function code 16)					
Parameter	Address	Data Format	Value range	Initial Value	Instruction
Cal point1 Cal	200	32 Bit Float	-	-	Write value 4 for pH 4.01 calibration
Cal point2 Cal	206	32 Bit Float	-	-	Write value 7 for pH 6.86 calibration
Cal point3 Cal	214	32 Bit Float	-	-	Write value 9 for pH 9.18 calibration

Recovery (write with function code 06)					
Parameter	Address	Data Format	Value range	Initial Value	Instruction
Restore setting parameters	400	Unsigned	-	-	Write the value of 99 to reset the setting parameters, but the communication setting will not be reset

4.3 How to use common functions

4.3.1 Reading electrode measurements

Read the pH value and temperature value measured by the electrode

(assuming the electrode address is 1)

Host sends **[01 04 00 02 00 04 50 09]**

[01] Indicates the electrode address, where the electrode address is 1

[04] Indicates the function code, here use the function code 04 to read the measured value

[00 02] Represents the starting register address, where the starting register address is 2

[00 04] Indicates the number of registers to be read, here 4 registers are read

[50 09] Indicates CRC check code

Electrode return data **[01 04 08 00 00 40 E0 00 00 41 C8 9A DD]**

[01] Indicates the electrode address, where the electrode address is 1

[04] Indicates the function code, here use the function code 04 to read the measured value

[08] Indicates the number of data bytes, there are 8 bytes here

[00 00 40 E0] These 4 bytes represent the ORP value, the value is represented by a floating point number, **[00 00]** is the lower 16 bits, **[40 E0]** is the upper 16 bits, that is, the 32-bit floating point number is **[40 E0 00 00]**, after converting to decimal, it is 7, and the mV value is 7

[00 00 41 C8] These 4 bytes represent the temperature value, the value is represented by a floating point number, **[00 00]** is the lower 16 bits, **[41 C8]** is the upper 16 bits, that is, the 32-bit floating point number is **[41 C8 00 00]**, converted to decimal number is 25, the temperature value is 25 degrees Celsius

[9A DD] Means CRC check code

4.3.2 Modify electrode address

Modify the electrode address, change the electrode address from 1 to 2

Host sends **[01 06 00 00 00 02 08 0B]**

4.3.3 Electrode calibration

Electrode calibration (assuming the electrode address is 1)

Zero calibration:

The calibration value is the value set by calibration point 2, the default is 6.86

Use function code 16 to write value 7 to register address 206 to perform calibration

Host send **[01 10 00 CE 00 02 04 00 00 40 E0 4E 3B]**

Slope 1 calibration:

The calibration value is the value set at calibration point one, the default is 4.01

Use function code 16 to write value 4 to register address 200 to perform calibration

Host send **[01 10 00 C8 00 02 04 00 00 40 80 CE 39]**

Slope 2 calibration:

The calibration value is the value set at calibration point three, the default is 9.18

Use function code 16 to write value 9 to register address 214 to perform calibration

Host sends **[01 10 00 D6 00 02 04 00 00 41 10 4F 45]**

4.3.4 Factory reset

Factory reset (communication parameters are not restored) (assuming the electrode address is 1)
Use function code 06 to write the value 99 to the register address 400 to perform recovery
Host sends [01 06 01 90 00 63 C8 32]

Chapter 5 Maintenance cycle

In order to obtain the best measurement results, regular maintenance is required. Maintenance includes cleaning of electrodes, and checking for damage.

5.1 Maintenance cycle

Maintenance work	Maintenance frequency
Visual inspection	Per month
Check calibration	Monthly (according to the environmental conditions of use)
Replace the pH sensor	Yearly (according to the environmental conditions of use)
Seal maintenance	Every two years

Note: The sensor seal should be maintained by the manufacturer's service department every 2 years. If not maintained regularly, water may enter the sensor and seriously damage the sensor.

5.2 Common problems and solutions

Phenomenon	Solutions
Electrodes cannot communicate	1. Check whether the electrode wiring is correct
	2. Check the communication setting parameters (address, baud rate, parity bit, stop bit)
The measured value is abnormal	1. Check whether the electrode bulb is cleaned and whether the sensor is damaged
	2. Restore the electrode to the factory calibration value, clean it and recalibrate it with a standard buffer
	3. Check the service life of the electrode



Delfino Environmental Technology Co., Ltd.

www.daruifuno.com

info@daruifuno.com